



Code EcoFast™ 01 & EcoFast™ 05

EcoFast™ 01:	Casing: White Powder Coat Steel 1.2mm Thickness
EcoFast™ 05:	Casing: #304 Satin Stainless Steel 1.2mm Thickness (as shown)
Features	Smallest high speed hand dryer in the world Patented free flow air system Lowest power consumption in the Eco Dryer market
Motor	500W Brush Type: Dual Ball Bearings, 29,000RPM 105°C auto resetting safety overload thermostat
Power Use	240V, 50Hz, 1000W, 4.17A
Sound Level	75db (+/- 3)
Drying Time	Less than 15 seconds
Drip Proof Rating	IPX 1
Heater Element	500W
Heater Assembly	85°C auto resetting thermostat
Warm Air Speed	90m/s
Warm Air Temp	Ambient +30°C
Timing Protection	60 seconds power safety cut off - auto reset
Sensor/Range	Infrared Automatic - 180mm +/-20mm preset 60 - 250mm adjustable distance
Casing Security	2 SS theft resistant hex drive screws (hex key supplied)
Net Weight	3.8kg
Dimensions	250mmW x 180mmH x 139mmD
Note	Unit can be hard wired by electrician or used with cord and plug provided Installation template & instructions included



Auto Operation Hand Dryer

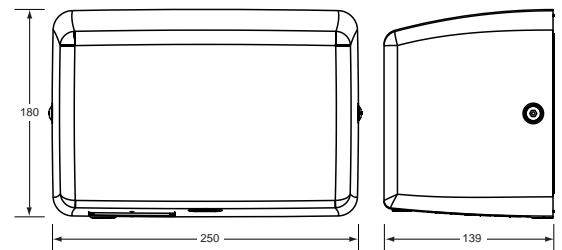

Code HK JA 05

Material	Casing: #304 Satin Stainless Steel, 1.5mm Thickness
Motor	350-700W Brush Type: Dual Ball Bearings 12,000-18,000RPM 105°C auto resetting safety overload thermostat
Power Use	240V, 50Hz, 1600W, 6.67A
Sound Level	78db (+/- 3)
Drying Time	Less than 15 seconds
Drip Proof Rating	IP 23
Heater Element	450-900W (adjustable)
Heater Assembly	85°C auto resetting safety thermal cut off
Warm Air Speed	75-100m/s (adjustable)
Warm Air Temp	Ambient +25°C
Overload Protection	Motor assembly designed with Over Heating Fuse (replaceable)
Timing Protection	60 seconds power safety cut off - auto reset
Sensor/Range	Infrared Automatic with hand positional violet LED 180mm +/- 20mm preset 60-330mm adjustable distance
Casing Security	2 SS theft resistant hex drive screws (hex key supplied)
Net Weight	5.8kg
Dimensions	205mmW x 287mmH x 180mmD
Note	Unit can be hard wired by electrician or used with cord and plug provided Installation template & instructions included



Auto Operation Hand Dryer

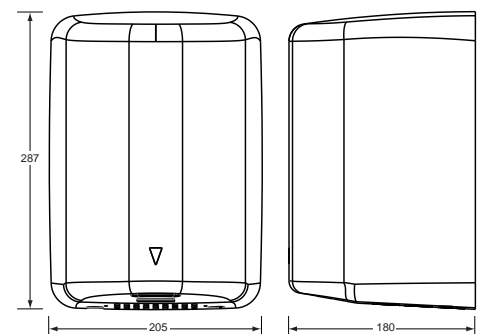

The photographs and line drawings of the products in this catalogue are representational only. Metlam Australia Pty Ltd reserves the right to, and from time to time, make changes and improvements in design and dimensions.



Code **HK QA**

Casing	#304 Satin Stainless Steel, 1.5mm Thickness
End Covers	High Grade ABS
Specify	Black, White or Red End Covers Alternate colours available (POA)
Motor	200W Brush Type: Dual Ball Bearings, 4150 RPM 105°C auto resetting safety overload thermostat
Power Use	240V, 50Hz, 2200W, 9.17A
Sound Level	68db (+/- 3)
Drying Time	Less than 15 seconds
Drip Proof Rating	IPX 1
Heater Element	2000W
Heater Assembly	87°C auto resetting thermostat 142°C auto resetting safety thermal cut off
Warm Air Speed	26m/s
Warm Air Temp	Ambient +30°C
Timing Protection	60 seconds power safety cut off - auto reset
Timing Duration	2 second delay turn off after last read
Sensor/Range	Infrared Automatic - 180mm +/-20mm preset 100 - 300mm adjustable distance
Casing Security	2 SS theft resistant hex drive screws (hex key supplied)
Net Weight	6.0kg
Dimensions	314mmW x 217mmH x 179mmD
Note	Unit can be hard wired by electrician or used with cord and plug provided Installation template & instructions included



Auto Operation Hand Dryer

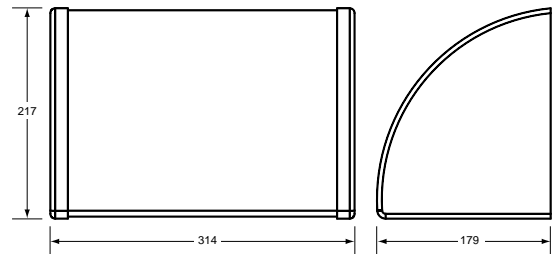

Code **HK 2200 SRA**

Material	Casing: #304 Satin Stainless Steel, 1.2mm Thickness
Motor	200W Brush Type, 4150 RPM 105°C auto resetting safety overload thermostat
Power Use	240V, 50Hz, 2200W, 9.17A
Sound Level	70db (+/- 3)
Drying Time	25-30 seconds
Drip Proof Rating	IPX 1
Heater Assembly	87°C auto resetting thermostat 142°C auto resetting safety thermal cut off
Warm Air Speed	20.5m/s
Warm Air Temp	Ambient +30°C
Timing Protection	60 seconds auto safety shut off - auto reset
Sensor/Range	Infrared Automatic - 180mm +/-20mm preset 100 - 300mm adjustable distance
Casing Security	2 SS theft resistant hex drive screws (hex key supplied)
Net Weight	6.1kg
Dimensions	320mmW x 220mmH x 175mmD
Note	Unit can be hard wired by electrician or used with cord and plug provided Installation template & instructions included



Auto Operation Hand Dryer

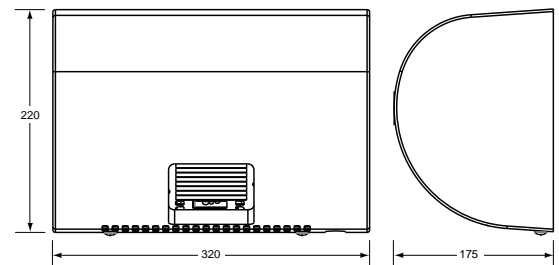

The photographs and line drawings of the products in this catalogue are representational only. Metlam Australia Pty Ltd reserves the right to, and from time to time, make changes and improvements in design and dimensions.



Code	HK 100 N
Material	Casing:#304 Satin Stainless Steel, 1.2mm Thickness
Motor	200W Brush Type: Dual Ball Bearings, 7500 RPM 105°C auto resetting safety overload thermostat
Power Use	240V, 50Hz, 2000W, 9.2A
Sound Level	70db (+/- 3)
Drying Time	Less than 15 seconds
Drip Proof Rating	IPX 1
Heater Element	2000W
Heater Assembly	87°C auto resetting thermostat 141°C auto resetting safety thermal cut off
Warm Air Speed	10.8m/s
Warm Air Temp	Ambient +20°C
Timing Protection	60 seconds power safety cut off - auto reset
Timing Duration	2 second delay turn off after last read
Sensor/Range	Infrared Automatic - 180mm +/-20mm preset 100 - 300mm adjustable distance
Casing Security	2 SS theft resistant hex drive screws (hex key supplied)
Net Weight	6.0kg
Dimensions	268mmW x 273mmH x 100mmD
Note	Unit can be hard wired by electrician or used with cord and plug provided Installation template & instructions included



Slimline Auto Operation Hand Dryer

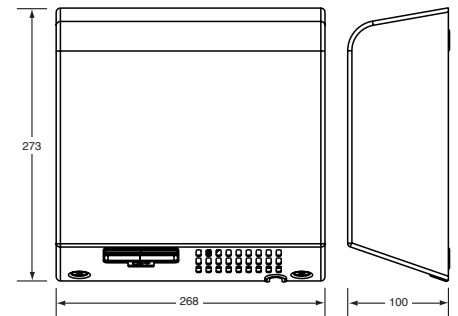

Code	HK 2200 SA (F)
Material	Casing:#304 Satin Stainless Steel, 1.2mm Thickness Nozzle: Diecast Zinc, Chrome Plated
Motor	100W Brushless, 2850 RPM 105°C auto resetting safety overload thermostat
Power Use	240V, 50Hz, 2200W, 9.17A
Sound Level	64db (+/- 3)
Drying Time	25-30 seconds
Drip Proof Rating	IPX 1
Heater Assembly	87°C auto resetting thermostat 142°C auto resetting safety thermal cut off
Warm Air Speed	14.5m/s
Warm Air Temp	Ambient +30°C
Timing Protection	60 seconds power safety cut off - auto reset
Sensor/Range	Infrared Automatic - 180mm +/-20mm preset 100 - 300mm adjustable distance
Casing Security	2 SS theft resistant hex drive screws (hex key supplied)
Net Weight	6.1kg
Dimensions	320mmW x 220mmH x 175mmD
Note	Unit can be hard wired by electrician or used with cord and plug provided Installation template & instructions included



Auto Operation Hand Dryer

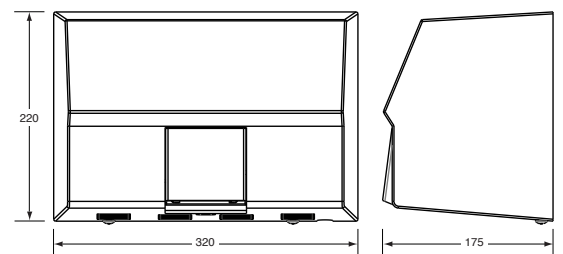

Specify **HK 2200 SS (F) - Push Button Operation**

Same as above except Push Button Operation





Code **HK 1800 PA**

Material	Casing: White High Grade Fire Retardant ABS, 3.0mm Thickness
Motor	80W Brushless, 2850 RPM 105°C auto resetting safety overload thermostat
Power Use	240V, 50Hz, 1800W, 7.50A
Sound Level	55db (+/- 3)
Drying Time	25-30 seconds
Drip Proof Rating	IPX 1
Heater Assembly	87°C auto resetting thermostat 142°C auto resetting safety thermal cut off
Warm Air Speed	14.5m/s
Warm Air Temp	Ambient +28°C
Timing Protection	60 seconds power safety cut off - auto reset
Sensor/Range	Infrared Automatic - 180mm +/-20mm preset 100 - 300mm adjustable distance
Casing Security	2 SS theft resistant hex drive screws (hex key supplied)
Net Weight	3.8kg
Dimensions	268mmW x 220mmH x 170mmD
Note	Unit can be hard wired by electrician or used with cord and plug provided Installation template & instructions included



Auto Operation Hand Dryer

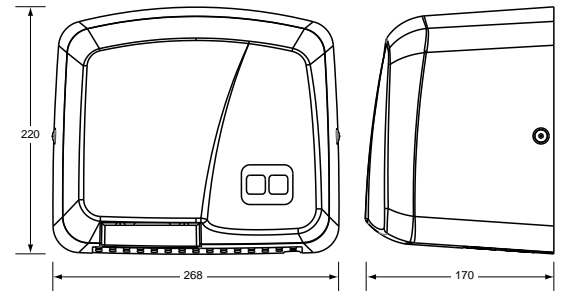

Code **HK 1800 PS**

Material	Casing: White High Grade Fire Retardant ABS, 3.0mm Thickness
Motor	80W Brushless, 2850 RPM 105°C auto resetting safety overload thermostat
Power Use	240V, 50Hz, 1800W, 7.50A
Sound Level	55db (+/- 3)
Drying Time	25-30 seconds
Drip Proof Rating	IPX 1
Heater Assembly	87°C auto resetting thermostat 142°C auto resetting safety thermal cut off
Warm Air Speed	14.5m/s
Warm Air Temp	Ambient +28°C
Timing Protection	60 seconds power safety cut off - auto reset
Sensor/Range	180mm +/-20mm preset 100 - 300mm adjustable distance
Casing Security	2 SS theft resistant hex drive screws (hex key supplied)
Net Weight	3.8kg
Dimensions	268mmW x 220mmH x 170mmD
Note	Unit can be hard wired by electrician or used with cord and plug provided Installation template & instructions included



Push Button Operation Hand Dryer

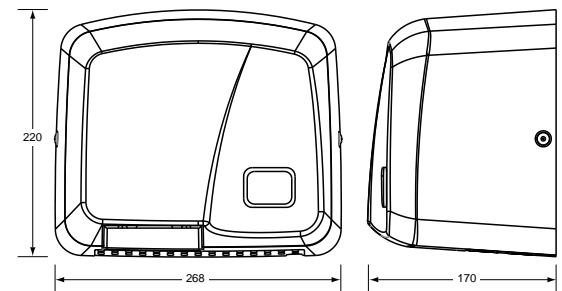

The photographs and line drawings of the products in this catalogue are representational only. Metlam Australia Pty Ltd reserves the right to, and from time to time, make changes and improvements in design and dimensions.



Code **HK 2200 EA**

Material	Casing: White Powder Coated Cast Aluminium
Motor	100W Brushless, 2850RPM 105°C auto resetting safety overload thermostat
Power Use	240V, 50Hz, 2200W, 9.10A
Sound Level	63db (+/- 3)
Drying Time	30-35 seconds
Drip Proof Rating	IPX 1
Heater Element	2100W
Heater Assembly	87°C safety overload thermostat 142°C safety thermal cut off
Warm Air Speed	15.5m/s
Warm Air Temp	Ambient 30°C
Timing Protection	60 seconds power safety cut off - auto reset
Sensor/Range	Infrared Automatic - 180mm +/-20mm preset 100 - 300mm adjustable distance
Casing Security	2 SS theft resistant hex drive screws (hex key supplied)
Net Weight	6.1kg
Dimensions	320mmW x 220mmH x 175mmD
Note	Unit can be hard wired by electrician or used with cord and plug provided Installation template & instructions included



Auto Operation Hand Dryer Powder Coat

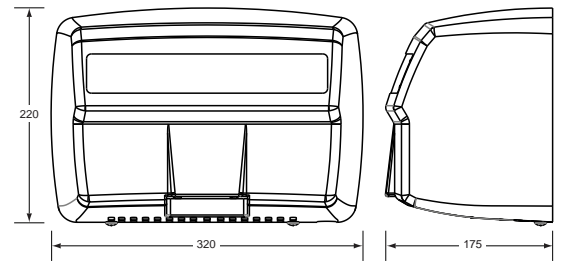

Code **HK 2400 PA**

Material	Casing: White Porcelain Enamel Coated Steel Nozzle: Chrome Plated Zinc
Specify	Bright Chrome Nozzle Satin Chrome Nozzle
Motor	200W Brush Type: Dual Ball Bearings, 5500RPM 105°C auto resetting safety overload thermostat
Power Use	240V, 50Hz, 2000-2400W, 9.15-10.0A
Sound Level	70db (+/- 3)
Drying Time	20-25 seconds
Drip Proof Rating	IPX 1
Heater Element	2200W
Heater Assembly	65°C auto resetting thermostat 142°C auto resetting safety thermal cut off
Warm Air Speed	28m/s
Warm Air Temp	Ambient +30°C
Timing Protection	60 seconds power safety cut off - auto reset
Sensor/Range	Infrared Automatic with hand postional violet LED 180mm +/-20mm preset 100 - 300mm Adjustable Distance
Casing Security	2 SS theft resistant hex drive screws (hex key supplied)
Net Weight	7.0kg
Dimensions	Unit: 284mmW x 247mmH x 213mmD Nozzle: 35mm projection - Fixed or 360° Rotation
Note	Unit can be hard wired by electrician or used with cord and plug provided Installation template & instructions included



Auto Operation Hand Dryer Porcelain

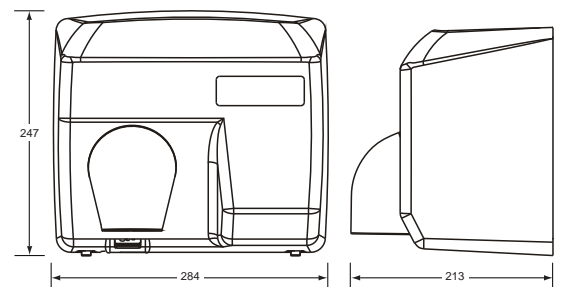

The photographs and line drawings of the products in this catalogue are representational only. Metlam Australia Pty Ltd reserves the right to, and from time to time, make changes and improvements in design and dimensions.



Code HK 2200 SAR

Material	Casing: #304 Satin Stainless Steel, Thickness: 2.0mm Facia Panel, 1.2mm Casing
Motor	200W Brush Type: Dual Ball Bearings, 4150RPM 105°C auto resetting safety overload thermostat
Power Use	240V, 50Hz, 2200W, 9.17A
Sound Level	70db (+/- 3)
Drying Time	Less than 25 seconds
Drip Proof Rating	IPX 1
Heater Element	2000W
Heater Assembly	87°C auto resetting thermostat 141°C auto resetting safety thermal cut off
Warm Air Speed	20.5m/s
Warm Air Temp	Ambient +30°C
Timing Protection	60 seconds power safety cut off - auto reset
Sensor/Range	Infrared Automatic - 180mm +/-20mm preset 60 - 330mm adjustable distance
Casing Security	4 SS theft resistant hex drive screws (hex key supplied)
Net Weight	8.8kg
Dimensions	
Unit	340mmW x 361mmH x 153mmD
Rough Wall Opening	323mmW x 346mmH x 160mmD
Note	Installation guide included



Auto Operation Cavity Hand Dryer

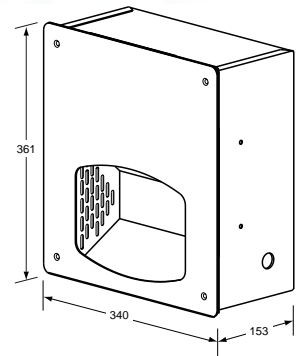

CE RoHS WEEE

Code HK 2400 SAR

Material	Casing: #304 Satin Stainless Steel, Thickness: 2.0mm Facia Panel, 1.2mm Casing Nozzle: Chrome Plated Zinc
Motor	200W Brush Type: Dual Ball Bearings, 5500RPM 105°C auto resetting safety overload thermostat
Power Use	240V, 50Hz, 2000-2400W, 10.0A
Sound Level	73db (+/- 3)
Drying Time	Less than 30 seconds
Drip Proof Rating	IPX 1
Heater Element	1800-2200W
Heater Assembly	65°C auto resetting thermostat
Warm Air Speed	28m/s
Warm Air Temp	Ambient +30°C
Overload Protection	Motor assembly designed with Over Heating Fuse (replaceable)
Timing Protection	60 seconds power cut off - auto reset
Sensor/Range	Infrared Automatic - 180mm +/- 20mm preset 100 - 300mm adjustable distance
Casing Security	4 SS theft resistant hex drive screws (hex key supplied)
Net Weight	9.0kg
Dimensions	
Unit	320mmW x 338mmH x 178mmD
Rough Wall Opening	295mmW x 313mmH x 175mmD
Nozzle	80mm projection
Note	Installation guide included



Auto Operation Nozzle Hand Dryer

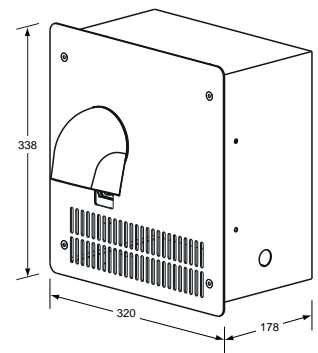

RoHS WEEE

The photographs and line drawings of the products in this catalogue are representational only. Metlam Australia Pty Ltd reserves the right to, and from time to time, make changes and improvements in design and dimensions.