

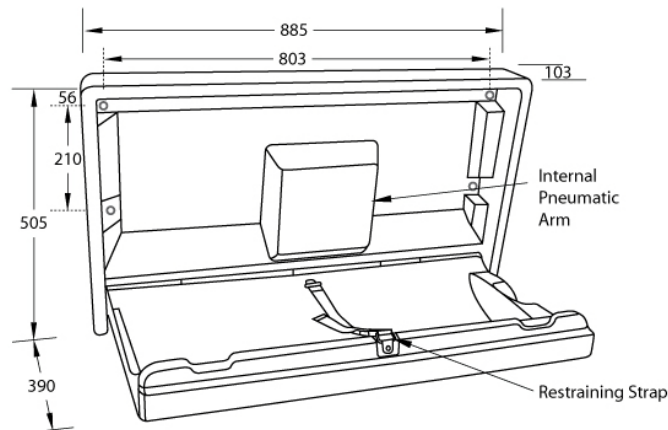

MATERIAL SPECIFICATION & INSTALLATION GUIDE

PRODUCT ITEM CODE & DESCRIPTION

ML 959-H ~ STANDARD BABY CHANGE STATION - HORIZONTAL MOUNT



MATERIAL SPECIFICATIONS/FEATURES:

Manufactured from Hi-Density Polypropylene; featuring concave change area & nylon safety restraining strap, hooks for bags/purses. Pneumatic non-visible arm provides safe, controlled opening/closing of change bed.

DIMENSIONS:

Overall –. Open/Closed ~ 885mm W x 505mm H x 493mm D / 885mm W x 505mm H x 103mm D

INSTALLATION GUIDE:

May be subject to local Council, architectural drawings and/or Building Code of Australia re height/location requirements, which are the installer's responsibility.

1. Locate height on wall and mark/drill mounting holes, ensuring fixings (not included) will secure into noggings or studwork if applicable.
2. Secure in place using 4 locating/fixing holes and suitable fasteners to ensure rigid fix.
3. Open/close unit to ensure smooth operation.

These units should only be installed by a competent tradesperson and Metlam Australia takes no responsibility for any damage to walls or fixtures due to incorrect installation.