

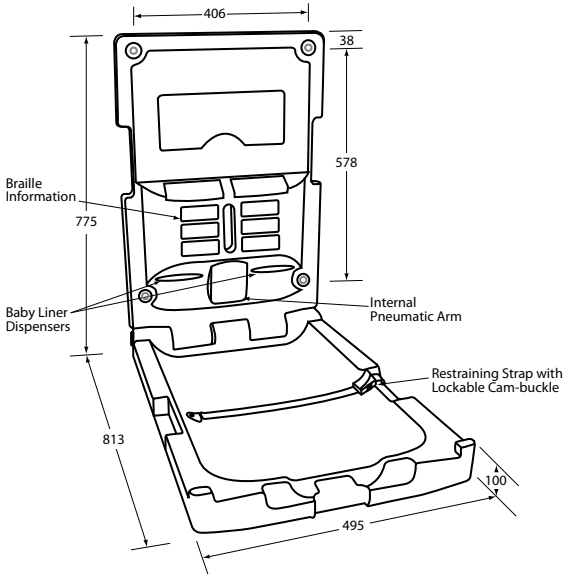

**Code** ML 9100 EV

- Material** Hi-density bacteria resistant Polyethylene body  
Stainless Steel hinge & mounting bracket
- Features** Concave change area  
Safety restraining strap fitted with lockable Cam-buckle for one handed adjustment & securing  
Dual bed liner dispensers  
Baby/shoulder bag retainers  
Pneumatic non visible Open/Close arm  
Braille information  
Suitable for up to 22.7kg use
- Overall Size**  
Open: 495mmW x 775mmH x 813mmD  
Closed: 495mmW x 813mmH x 100mmD



## Slimline Vertical Baby Change Station



**Code** ML 9100 EH

- Material** Hi-density bacteria resistant Polyethylene body  
Stainless Steel hinge & mounting bracket
- Features** Concave change area  
Safety restraining strap fitted with lockable Cam-buckle for one handed adjustment & securing  
Dual bed liner dispensers  
Baby/shoulder bag retainers  
Pneumatic non visible Open/Close arm  
Braille information  
Suitable for up to 22.7kg use
- Overall Size**  
Open: 870mmW x 390mmH x 445mmD  
Closed: 870mmW x 445mmH x 100mmD

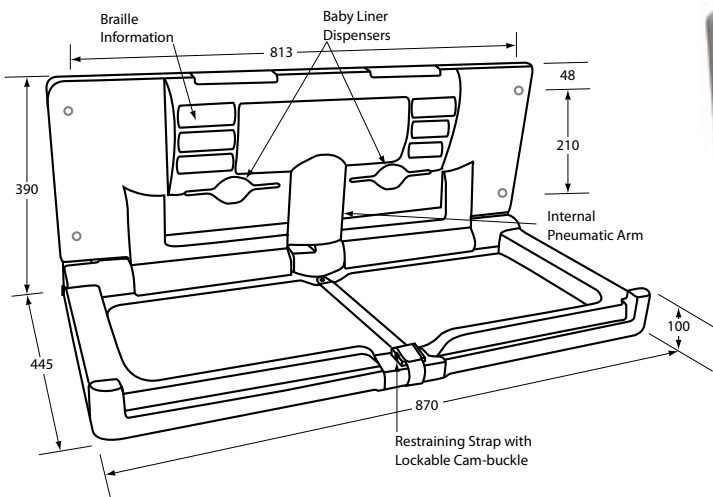

## Slimline Horizontal Baby Change Station



The photographs and line drawings of the products in this catalogue are representational only. Metlam Australia Pty Ltd reserves the right to, and from time to time, make changes and improvements in design and dimensions.